

Known errors in *Knowledge-Based Systems for Engineers and Scientists*, edition 2, Imprint 2

This list of errata applies **only** to imprint 2 of the book by Adrian A. Hopgood.

Page 111

In Figure 4.13, Class C should include att6 instead of att1. The revised version of Figure 4.13 is shown below:

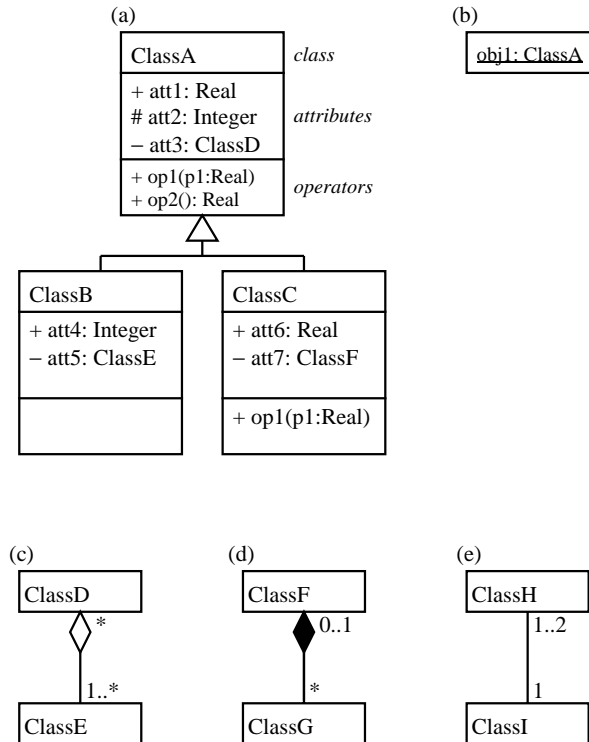

Page 171

The label on the vertical axis of Figure 7.2(a) should read:

$$P = 1 \text{ if } \Delta E < 0, \text{ else } P = \exp(-\Delta E / T)$$

Page 198

The opening paragraph of Section 8.2.4 should read as follows:

The use of a neural network as a content-addressable memory is a form of supervised learning. During training, each example input vector becomes stored in a dispersed form through the network. There are no separate desired output vectors associated with the training data, as the training data represent both the inputs and the desired outputs.

Page 205

Equation 8.6 should contain the symbol Δ before the second w_{Bij} . This equation should read:

$$\Delta w_{Bij} = \eta \delta_{Bi} y_{Aj} + \alpha (\Delta w_{Bij}) \quad (8.6)$$

Page 215

Errors have occurred in Figure 8.14. The quotient line (i.e. the horizontal line in a fraction) is missing from the definitions of closeness and of b_{kj} . Also, in the definition of closeness, there should be vertical bars around the x_j under the quotient line to indicate that its magnitude is used. The correct version of Figure 8.14 is shown below:

